

AIR OPERATED DOUBLE DIAPHRAGM PUMPS

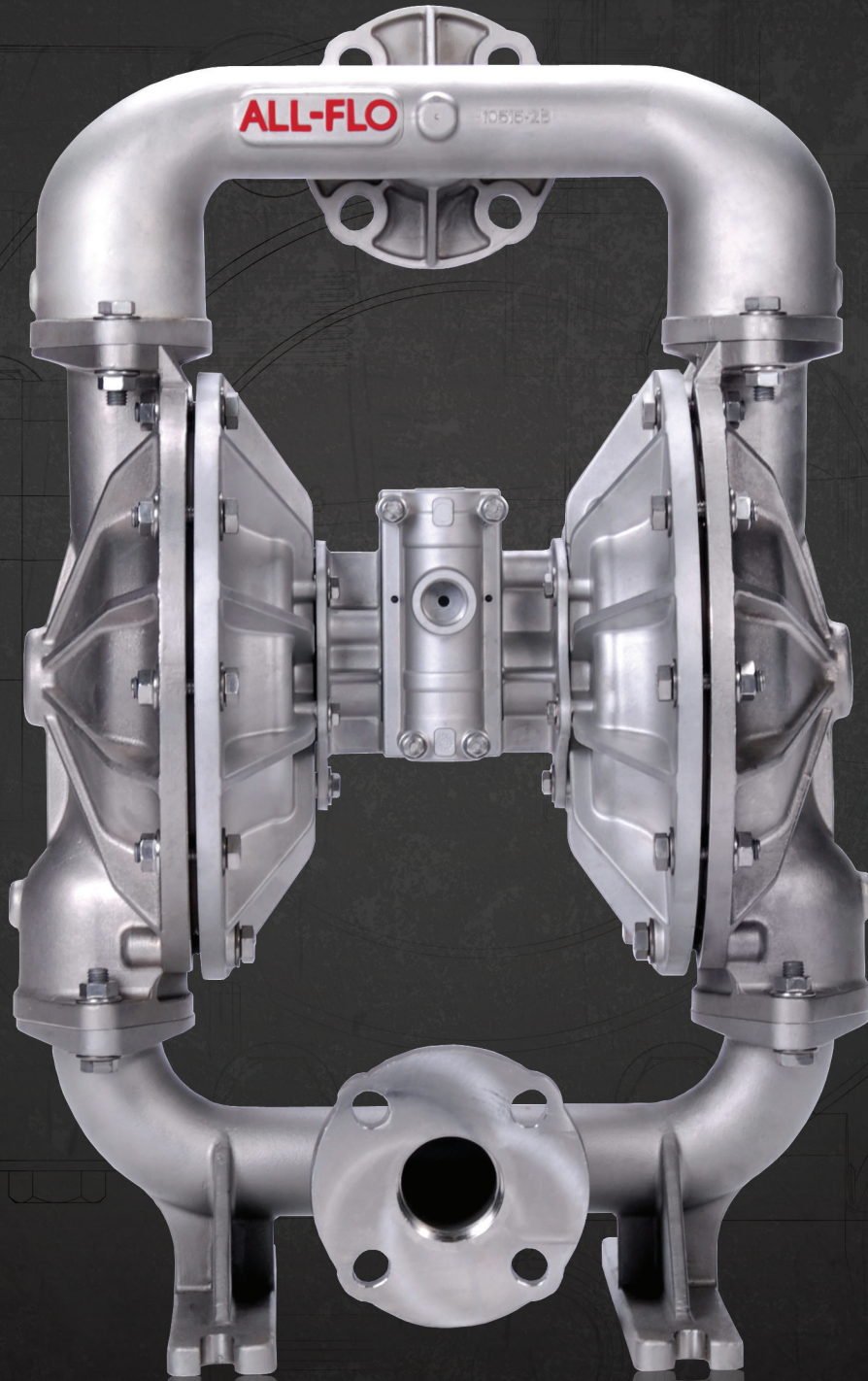

A REVOLUTION IN PUMPING EFFICIENCY

INTRODUCING THE NEW ALL-FLO PUMP.

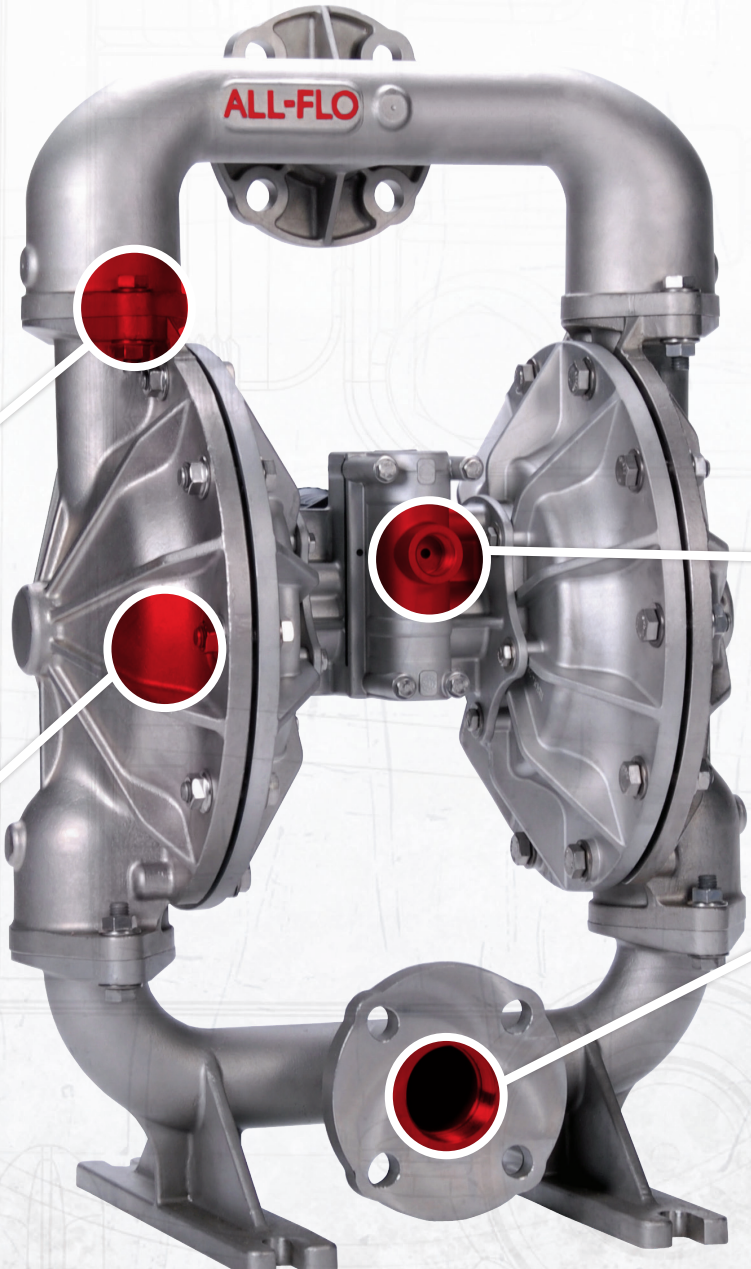

SIMPLE
A simple leak free bolted design ensures quick and easy repairs

PERFORMANCE
Quality-built construction of All-Flo pumps delivers unmatched efficiency and performance

EFFICIENCY
A high-efficiency air-valve dramatically reduces overall operating costs

COMPATIBILITY
Mounting feet and liquid porting location designed to match competitors' footprint, reducing replacement cost

TABLE OF CONTENTS

METAL PUMPS

1/2 AND 3/4 INCH PAGE 3

1 AND 1-1/2 INCH PAGE 4

2 AND 3 INCH PAGE 5

PLASTIC PUMPS

1/4 AND 3/8 INCH PAGE 6

1/2 AND 3/4 INCH PAGE 7

1 AND 1-1/2 INCH PAGE 8

2 AND 3 INCH PAGE 9

SPECIALTY PUMPS PAGES 10-11

ACCESSORIES PAGES 11-12

MATERIALS OF CONSTRUCTION PAGE 13

DATA ADDENDUM DETAILS PAGE 14

DESIGNED TO REDUCE ENERGY COSTS.

Designed to ensure significant energy savings for customers, All-Flo pumps raise the bar on efficiency standards across the industry. The newly-designed All-Flo pumps boast a high-efficiency air valve, making them the most energy efficient and cost-effective pumps in the industry.



SIMPLE DESIGN
All-Flo's simple air valve design allows for maximum efficiency



OPERATING COSTS
All-Flo pumps yield energy savings of 35-67% over competing pumps

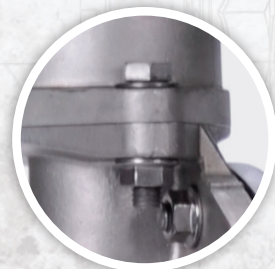

SIMPLE REPAIR
Simple leak free bolted design promotes swift and seamless repairs



CONNECTION & FOOTPRINT
Rest easy — multiple connection types & footprint to match competitors' models

PERFECT IN ANY INDUSTRY

AUTOMOTIVE

CERAMICS

CHEMICAL PROCESSING

CONSTRUCTION

ENVIRONMENTAL

FINISHING

FOOD & BEVERAGE

MARINE

MINING

OIL & GAS

PAINTS & COATINGS

PETROCHEMICAL

PHARMACEUTICAL

PLATING

PRIMARY METALS

PULP & PAPER

REFINING



METAL - 1/2 INCH AND 3/4 INCH

1/2 INCH

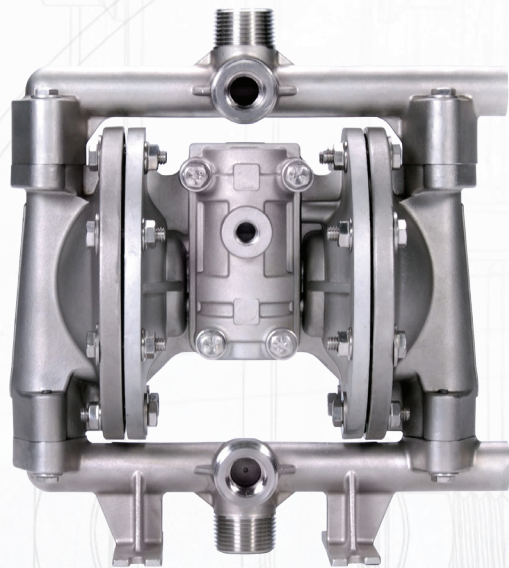

Materials of Construction

Liquid Section:	Aluminum, Anodized Aluminum and Stainless Steel
Air Section:	Aluminum and Polypropylene
Elastomers:	Geolast [®] , Santoprene [®] , Viton [®] and PTFE

Performance Specifications

Max. Flow:	14 gpm (53.0 lpm)
Max. Air Pressure:	120 psi (8.3 bar)
Max. Solids:	1/8" (3.2 mm)
Max. Suction Lift Dry:	15 ft-H ₂ O (4.5 m-H ₂ O)
Max. Suction Lift Dry w/ PTFE:	14 ft-H ₂ O (4.3 m-H ₂ O)
Max. Suction Lift Wet:	31 ft-H ₂ O (9.4 m-H ₂ O)
Weight Aluminum:	10 lbs (4.5 kg)
Weight Stainless Steel:	20 lbs (9.1 kg)
Air Inlet:	1/4" FNPT
Liquid Inlet:	1/2" FNPT or FBSPT
Liquid Outlet:	1/2" FNPT or FBSPT
Height:	11.2" (284 mm)
Width:	10.3" (262 mm)
Depth:	6.4" (163 mm)*

*Polypropylene air section (intermediate) has depth of 7.3" (185mm).

Materials of Construction

Liquid Section:	Aluminum, Anodized Aluminum and Stainless Steel
Air Section:	Aluminum and Polypropylene
Elastomers:	Geolast [®] , Santoprene [®] , Viton [®] and PTFE

Performance Specifications

Max. Flow:	14 gpm (53.0 lpm)
Max. Air Pressure:	120 psi (8.3 bar)
Max. Solids:	1/8" (3.2 mm)
Max. Suction Lift Dry:	15 ft-H ₂ O (4.5 m-H ₂ O)
Max. Suction Lift Dry w/ PTFE:	14 ft-H ₂ O (4.3 m-H ₂ O)
Max. Suction Lift Wet:	31 ft-H ₂ O (9.4 m-H ₂ O)
Weight Aluminum:	10 lbs (4.5 kg)
Weight Stainless Steel:	20 lbs (9.1 kg)
Air Inlet:	1/4" FNPT
Liquid Inlet:	3/4" FNPT or FBSPT (Center Port Only)
Liquid Outlet:	3/4" FNPT or FBSPT (Center Port Only)
Height:	11.2" (284 mm)
Width:	10.3" (262 mm)
Depth:	6.4" (163 mm)*

3/4 INCH

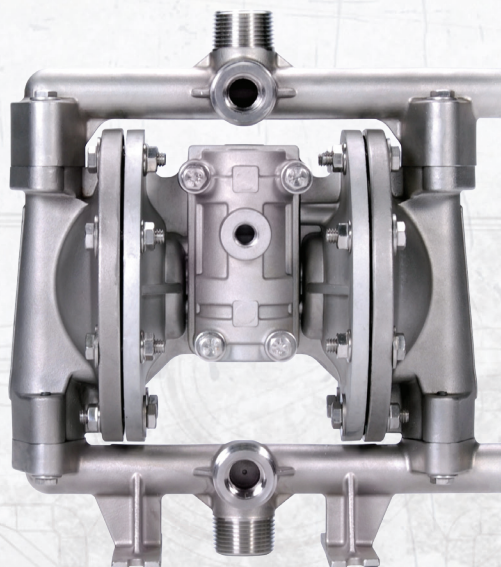

METAL - 1 INCH AND 1-1/2 INCH

1 INCH

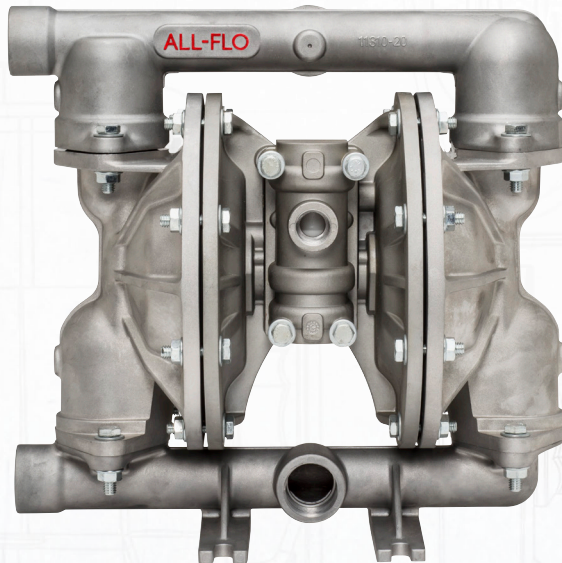

Materials of Construction

Liquid Section:

Aluminum, Anodized Aluminum, and Stainless Steel

Air Section: Aluminum and Stainless Steel

Elastomers:

Geolast®, Santoprene®, Viton®, PTFE, Buna-N and EPDM

Performance Specifications (1-1/2" Ports)

Max. Flow:	115 gpm (435 lpm)
Max. Air Pressure:	120 psi (8.3 bar)
Max. Solids:	1/4" (6.4 mm)
Max. Suction Lift Dry:	22 ft-H ₂ O (6.7 m-H ₂ O)
Max. Suction Lift Dry w/ PTFE:	18 ft-H ₂ O (5.5 m-H ₂ O)
Max. Suction Lift Wet:	31 ft-H ₂ O (9.4 m-H ₂ O)
Weight Aluminum:	45 lbs (20 kg)
Weight Stainless Steel:	70 lbs (32 kg) Threaded
Weight Stainless Steel:	84 lbs (38 kg) Flange
Air Inlet:	3/4" FNPT
Liquid Inlet:	Aluminum 1-1/2" FNPT, FBSPT Stainless Steel 1-1/2" FNPT, FBSPT, or ANSI/DIN Flange
Liquid Outlet:	Aluminum 1-1/2" FNPT, FBSPT or 1-1/4" FNPT, FBSP (Top Port) Stainless Steel 1-1/2" FNPT, FBSPT, or ANSI/DIN Flange
Height:	17.3" (439 mm) Threaded / 23.9" (607 mm) Flange
Width:	20.8" (528 mm) Threaded / 18.8" (478 mm) Flange
Depth:	11.2" (284 mm) Threaded and Flange

Materials of Construction

Liquid Section:

Aluminum, Anodized Aluminum and Stainless Steel

Air Section:

Aluminum

Elastomers:

Geolast®, Santoprene®, Viton®, PTFE, Buna-N and EPDM

Performance Specifications

Max. Flow:	48 gpm (182 lpm)
Max. Air Pressure:	120 psi (8.3 bar)
Max. Solids:	1/4" (6.4 mm)
Max. Suction Lift Dry:	17 ft-H ₂ O (5.2 m-H ₂ O)
Max. Suction Lift Dry w/ PTFE:	17 ft-H ₂ O (5.2 m-H ₂ O)
Max. Suction Lift Wet:	30 ft-H ₂ O (9.1 m-H ₂ O)
Weight Aluminum:	18 lbs (8 kg)
Weight Stainless Steel:	38 lbs (17 kg)
Air Inlet:	1/4" FNPT
Liquid Inlet:	1" FNPT or FBSPT
Liquid Outlet:	1" FNPT or FBSPT
Height:	12.4" (315 mm)
Width:	13.0" (330 mm)
Depth:	8.4" (213 mm)

1-1/2 INCH

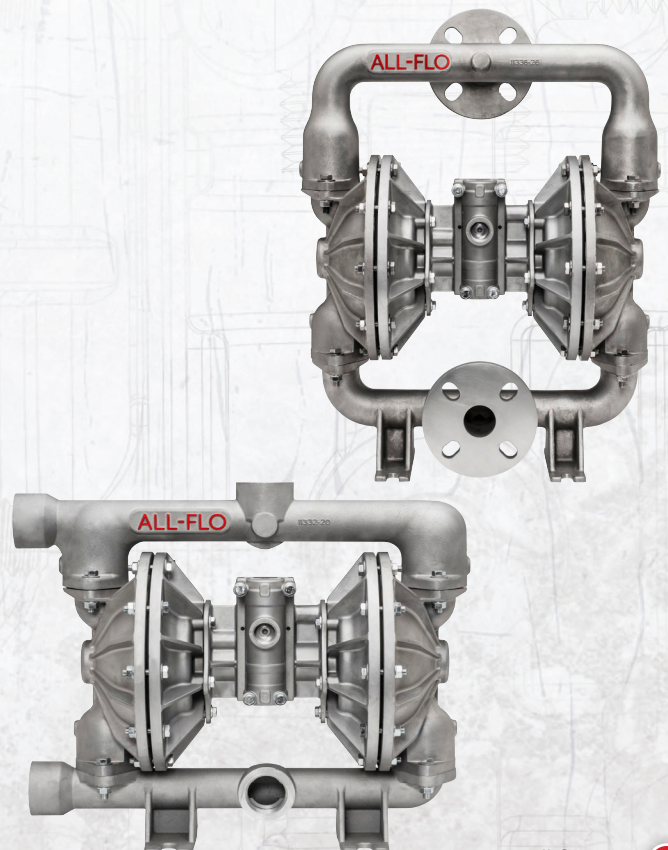

METAL - 2 INCH AND 3 INCH

2 INCH

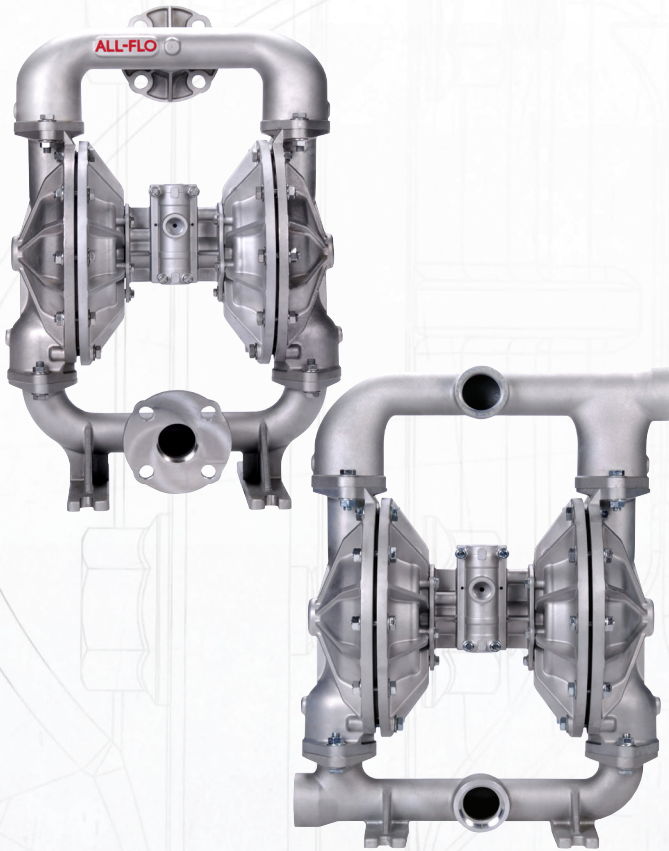

Materials of Construction

Liquid Section:	Aluminum, Anodized Aluminum and Stainless Steel
Air Section:	Aluminum and Stainless Steel
Elastomers:	Geolast®, Santoprene®, Viton®, PTFE, Buna-N and EPDM

Performance Specifications

Max. Flow:	190 gpm (719 lpm)
Max. Air Pressure:	120 psi (8.3 bar)
Max. Solids:	1/4" (6.4 mm)
Max. Suction Lift Dry:	24.4 ft-H ₂ O (7.4 m-H ₂ O)
Max. Suction Lift Dry w/ PTFE:	19.3 ft-H ₂ O (5.9 m-H ₂ O)
Max. Suction Lift Wet:	31.7 ft-H ₂ O (9.7 m-H ₂ O)
Weight Aluminum:	62 lbs (28 kg)
Weight Stainless Steel:	130 lbs (59 kg)
Air Inlet:	3/4" FNPT
Liquid Inlet:	Aluminum 2" FNPT or FBSP Stainless Steel 2" FNPT, FBSP or ANSI/DIN Flange
Liquid Outlet:	Aluminum 2" FNPT or FBSP Stainless Steel 2" FNPT, FBSP or ANSI/DIN Flange
Height:	26.3" (668 mm) AL / 29.5" (749 mm) SS
Width:	19.5" (495 mm) AL / 19.1" (485 mm) SS
Depth:	13.5" (343 mm) AL / 14.9" (378 mm) SS

Materials of Construction

Liquid Section:	Aluminum and Anodized Aluminum
Air Section:	Aluminum
Elastomers:	Geolast®, Santoprene®, Viton® and PTFE

Performance Specifications

Max. Flow:	235 gpm (890 lpm)
Max. Air Pressure:	120 psi (8.2 bar)
Max. Solids:	7/16" (11.1 mm)
Max. Suction Lift Dry:	20 ft-H ₂ O (6.1 m-H ₂ O)
Max. Suction Lift Dry w/ PTFE:	17 ft-H ₂ O (5.2 m-H ₂ O)
Max. Suction Lift Wet:	31 ft-H ₂ O (9.4m-H ₂ O)
Weight:	135 lbs (62 kg)
Air Inlet:	3/4" FNPT
Liquid Inlet:	3" FNPT or FBSP
Liquid Outlet:	3" FNPT or FBSP
Height:	32.6" (827 mm)
Width:	24.8" (633 mm)
Depth:	16.8" (425 mm)

3 INCH

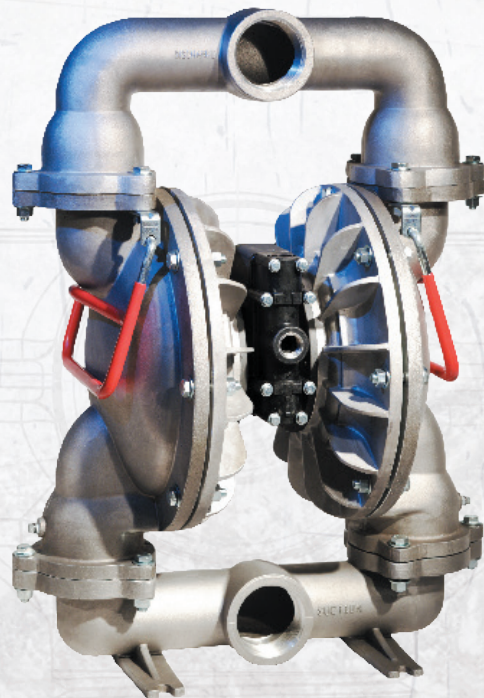

PLASTIC - 1/4 INCH AND 3/8 INCH

1/4 INCH



Materials of Construction

Liquid Section:	Polypropylene, PVDF
Air Section:	Polypropylene
Elastomers:	Geolast®, Santoprene® and PTFE

Performance Specifications

Max. Flow:	5.7 gpm (21.6 lpm)
Max. Air Pressure:	120 psi (8.3 bar)
Max. Solids:	1/16" (1.6 mm)
Max. Suction Lift Dry:	15 ft-H ₂ O (4.6 m-H ₂ O)
Max. Suction Lift Dry w/ PTFE:	10 ft-H ₂ O (3.0 m-H ₂ O)
Max. Suction Lift Wet:	28 ft-H ₂ O (8.5 m-H ₂ O)
Avg. Displacement Per Stroke:	0.0105 gallons (0.0397 l)
Weight Polypropylene:	2.6 lbs (1.2 kg)
Weight PVDF:	3.8 lbs (1.7 kg)
Air Inlet:	1/4" FNPT
Liquid Inlet:	1/4" internal (NPT/BSP), 3/4" external (NPT)
Liquid Outlet:	1/4" internal (NPT/BSP), 3/4" external (NPT)
Height:	6.8" (173 mm)
Width:	7.3" (186 mm)
Depth:	4.6" (118 mm)

Materials of Construction

Liquid Section:	Polypropylene, PVDF and Conductive Nylon
Air Section:	Polypropylene
Elastomers:	Geolast®, Santoprene®, Viton® and PTFE

Performance Specifications

Max. Flow:	9 gpm (34 lpm)
Max. Air Pressure:	120 psi (8.2 bar)
Max. Solids:	1/16" (1.6 mm)
Max. Suction Lift Dry:	15 ft-H ₂ O (4.5 m-H ₂ O)
Max. Suction Lift Dry w/ PTFE:	10 ft-H ₂ O (3 m-H ₂ O)
Max. Suction Lift Wet:	26 ft-H ₂ O (7.9m-H ₂ O)
Weight Polypropylene:	3.8 lbs (1.7 kg)
Weight PVDF & Conductive Nylon:	5 lbs (2.3kg)
Air Inlet:	1/4" FNPT
Liquid Inlet:	3/8" FNPT/FBSPT
Liquid Outlet:	3/8" FNPT/FBSPT
Height:	7.19" (183 mm)
Width:	8.55" (217 mm)
Depth:	4.82" (122 mm)

3/8 INCH

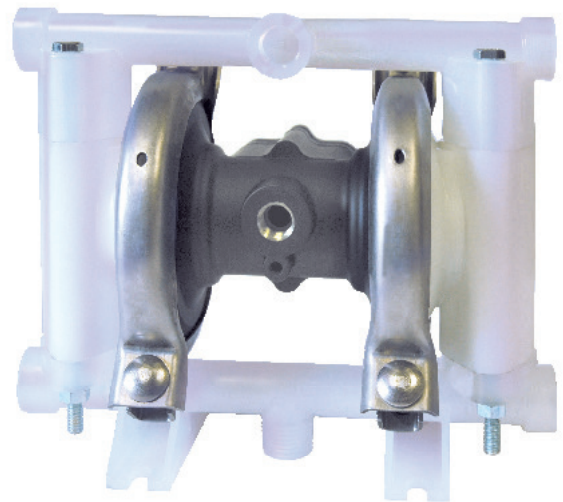

PLASTIC - 1/2 INCH AND 3/4 INCH

1/2 INCH

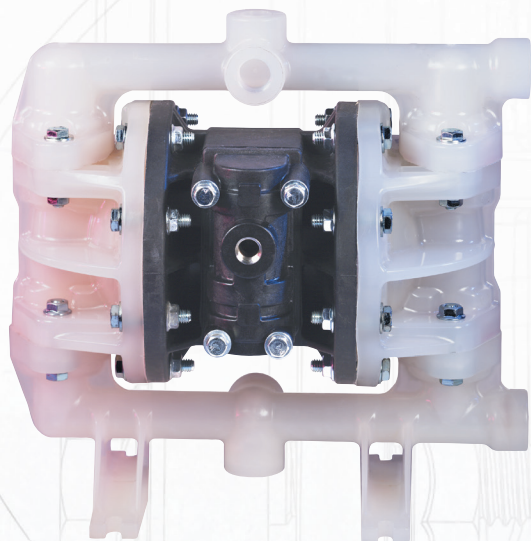

Materials of Construction

Liquid Section:	Polypropylene, PVDF and Conductive Nylon
Air Section:	Polypropylene
Elastomers:	Geolast®, Santoprene®, Viton® and PTFE

Performance Specifications

Max. Flow:	17 gpm (64.6 lpm)
Max. Air Pressure:	120 psi (8.2 bar)
Max. Solids:	1/8" (3.2 mm)
Max. Suction Lift Dry:	15 ft-H ₂ O (4.5 m-H ₂ O)
Max. Suction Lift Dry w/ PTFE:	10 ft-H ₂ O (3 m-H ₂ O)
Max. Suction Lift Wet:	26 ft-H ₂ O (7.9m-H ₂ O)
Weight Polypropylene:	9 lbs (4.1 kg)
Weight PVDF & Conductive Nylon:	12 lbs (5.4 kg)
Air Inlet:	1/4" FNPT
Liquid Inlet:	3/4" FNPT/FBSPT
Liquid Outlet:	3/4" FNPT/FBSPT
Height:	11.36" (289 mm)
Width:	12.04" (306 mm)
Depth:	7.37" (187 mm)

Materials of Construction

Liquid Section:	Polypropylene, PVDF and Conductive Nylon
Air Section:	Polypropylene
Elastomers:	Geolast®, Santoprene®, Viton® and PTFE

Performance Specifications

Max. Flow:	17 gpm (64.6 lpm)
Max. Air Pressure:	120 psi (8.2 bar)
Max. Solids:	1/8" (3.2 mm)
Max. Suction Lift Dry:	15 ft-H ₂ O (4.5 m-H ₂ O)
Max. Suction Lift Dry w/ PTFE:	10 ft-H ₂ O (3 m-H ₂ O)
Max. Suction Lift Wet:	26 ft-H ₂ O (7.9m-H ₂ O)
Weight Polypropylene:	9 lbs (4.1 kg)
Weight PVDF & Conductive Nylon:	12 lbs (5.4 kg)
Air Inlet:	1/4" FNPT
Liquid Inlet:	1/2" FNPT/FBSPT
Liquid Outlet:	1/2" FNPT/FBSPT
Height:	11.36" (289mm)
Width:	12.04" (306 mm)
Depth:	7.37" (187 mm)

3/4 INCH

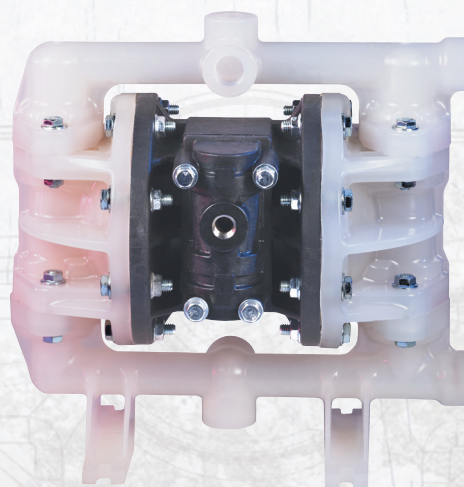

PLASTIC - 1 INCH AND 1-1/2 INCH

1 INCH

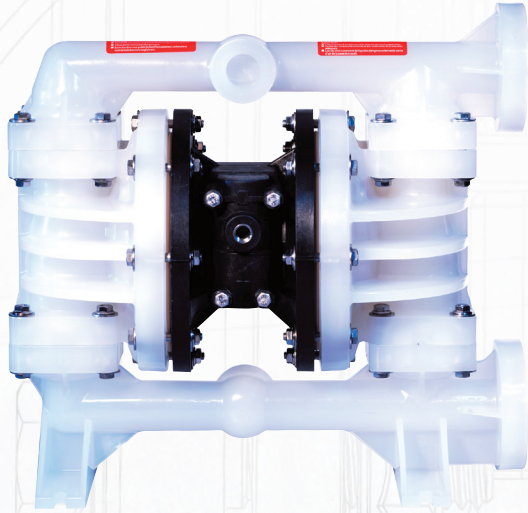

Materials of Construction

Liquid Section:	Polypropylene and PVDF
Air Section:	Polypropylene
Elastomers:	Geolast®, Santoprene®, Viton® and PTFE

Performance Specifications

Max. Flow:	41 gpm (155.8 lpm)
Max. Air Pressure:	120 psi (8.2 bar)
Max. Solids:	1/4" (6.4 mm)
Max. Suction Lift Dry:	15 ft-H ₂ O (4.5 m-H ₂ O)
Max. Suction Lift Dry w/ PTFE:	10 ft-H ₂ O (3 m-H ₂ O)
Max. Suction Lift Wet:	26 ft-H ₂ O (7.9m-H ₂ O)
Weight Polypropylene:	26 lbs (11.8 kg)
Weight PVDF:	36 lbs (16.3 kg)
Air Inlet:	1/4" FNPT
Liquid Inlet:	1" FNPT, FBSPT or ANDI/DIN Flange
Liquid Outlet:	1" FNPT, FBSPT or ANDI/DIN Flange
Height:	16.32" (415 mm)
Width:	17.26" (438 mm)
Depth:	8.88" (226 mm)

Materials of Construction

Liquid Section:	Polypropylene and PVDF
Air Section:	Polypropylene
Elastomers:	Geolast®, Santoprene®, Viton® and PTFE

Performance Specifications

Max. Flow:	130 gpm (492 lpm)
Max. Air Pressure:	120 psi (8.2 bar)
Max. Solids:	1/4" (6.4 mm)
Max. Suction Lift Dry:	13 ft-H ₂ O (3.9 m-H ₂ O)
Max. Suction Lift Dry w/ PTFE:	10 ft-H ₂ O (3 m-H ₂ O)
Max. Suction Lift Wet:	26 ft-H ₂ O (7.9 m-H ₂ O)
Weight Polypropylene:	59 lbs (26.8 kg)
Weight PVDF:	78 lbs (35.4 kg)
Air Inlet:	3/4" FNPT
Liquid Inlet:	1-1/2" ANDI/DIN Flange
Liquid Outlet:	1-1/2" ANDI/DIN Flange
Height:	20.40" (518 mm)
Width:	20.58" (523 mm)
Depth:	12.00" (305 mm)

1-1/2 INCH

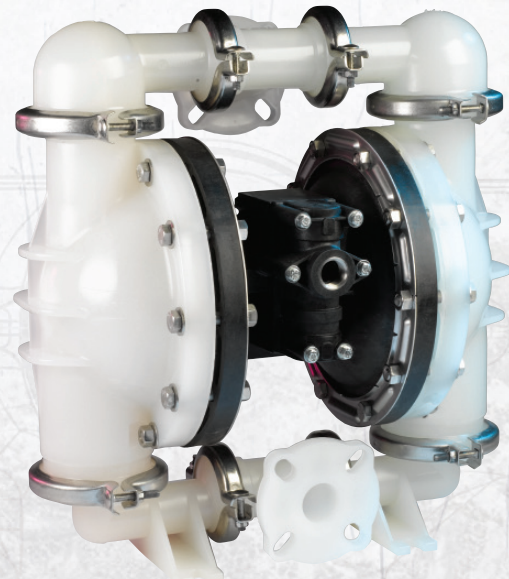

PLASTIC - 2 INCH AND 3 INCH

2 INCH



Materials of Construction

Liquid Section:	Polypropylene and PVDF
Air Section:	Polypropylene
Elastomers:	Geolast®, Santoprene®, Viton® and PTFE

Performance Specifications

Max. Flow:	180 gpm (681 lpm)
Max. Air Pressure:	120 psi (8.2 bar)
Max. Solids:	1/4" (6.4 mm)
Max. Suction Lift Dry:	13 ft-H ₂ O (3.9m-H ₂ O)
Max. Suction Lift Dry w/ PTFE:	10 ft-H ₂ O (3 m-H ₂ O)
Max. Suction Lift Wet:	26 ft-H ₂ O (7.9m-H ₂ O)
Weight Polypropylene:	61 lbs (27.7 kg)
Weight PVDF:	82 lbs (37.2 kg)
Air Inlet:	3/4" FNPT
Liquid Inlet:	2" ANDI/DIN Flange
Liquid Outlet:	2" ANDI/DIN Flange
Height:	25.00" (635 mm)
Width:	20.58" (523 mm)
Depth:	12.10" (307 mm)

Materials of Construction

Liquid Section:	HDPE
Air Section:	HDPE
Elastomers:	PTFE and EPDM

Performance Specifications

Max. Flow:	211 gpm (800 lpm)
Max. Air Pressure:	120 psi (8.2 bar)
Max. Solids:	9/16" (15 mm)
Max. Suction Lift Dry:	16.4 ft-H ₂ O (5 m-H ₂ O)
Max. Suction Lift Dry w/ PTFE:	10 ft-H ₂ O (3 m-H ₂ O)
Max. Suction Lift Wet:	29.5 ft-H ₂ O (9m-H ₂ O)
Weight:	374 lbs (170 kg)
Air Inlet:	3/4" FNPT
Liquid Inlet:	3" ANSI or DIN Flange
Liquid Outlet:	3" ANSI or DIN Flange
Height:	33.07" (840 mm)
Width:	22.83" (580 mm)
Depth:	18.90" (480 mm)

3 INCH



SPECIALTY PUMPS

PTFE (HIGH PURITY)



Materials of Construction

Liquid Section:	PTFE
Air Section:	HDPE
Elastomers:	Integral PTFE
Liquid Connection:	FNPT or BSPT, ANSI or DIN Flange
Available Sizes:	1/4 Inch, 3/8 Inch, 1/2 Inch, 1 Inch, 1-1/2 Inch and 2 Inch

*Other Flange Connections available upon request.

Materials of Construction

Liquid Section:	Electropolished and Passivated Stainless Steel
Air Section:	Aluminum
Elastomers:	FDA Hytrel®, FDA Santoprene® and FDA PTFE
Liquid Connection:	Tri-Clamp
Available Sizes:	1 Inch, 1-1/2 Inch and 2 Inch

ALL-PUR™ FDA

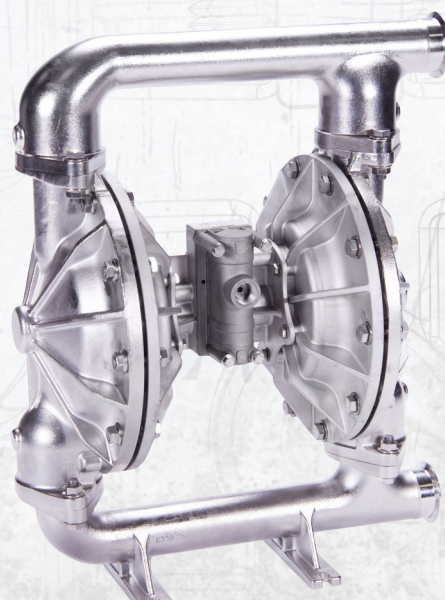

ALL-PUR™ FDA PUMPS

Electropolished and passivated 316 SS with FDA approved elastomers and tri-clamps for sanitary applications.



SPECIALTY PUMPS & PUMP ACCESSORIES

MAX-PASS™

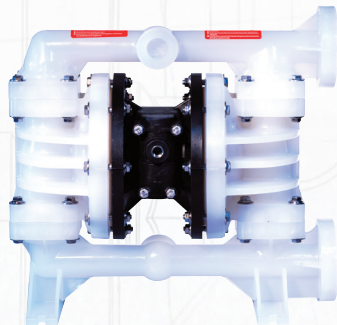
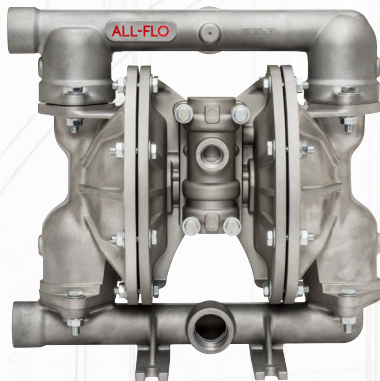

Materials of Construction

Liquid Section:

Aluminum, Anodized Aluminum and Stainless Steel

Air Section:

Aluminum

Elastomers:

Geolast®, Santoprene®, Viton® and PTFE

Available Sizes:

3/8 Inch, 1/2 Inch, 3/4 Inch and 1 Inch

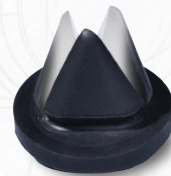

MAX-PASS™ SOLIDS HANDLING VALVE

- Increased suction lift
- Mounts in any position
- Increased solids handling capability

Materials of Construction

Liquid Section:

Aluminum, Polyethylene, PTFE and Stainless Steel

Materials of Airside:

Polyethylene and
Conductive Polyethylene

Bladder Material:

EPDM, Buna-N and PTFE

Liquid Connection:

FNPT, BSPT, ANDSI Flange and
DIN Flange

Available Sizes:

3/8 Inch, 1/2 Inch, 3/4 Inch, 1 Inch,
1-1/2 Inch, 2 Inch and 3 Inch

PULSATION DAMPENER



PUMP ACCESSORIES



DRUM PUMP KIT

Drum pump kits contain suction tube and bung adaptor. Drum pump kits are sold separately from pump. Details can be found in technical addendum or by contacting us directly.



FILTER/REGULATOR WITH GAUGE

Adjust and set air pressure to a set value with a combination filter regulator and pressure gauge unit. Specifications and drawing details available at www.all-flo.com.



MUFFLER

Standard plastic mufflers are sold with pump. Enhanced metal mufflers are available. Refer to parts list for enhanced muffler part number.



SOLENOID VALVES

Remotely start and stop with an in-line solenoid valve for the pump's air line. Specifications and drawing details available at www.all-flo.com.



GROUNDING ACCESSORIES

Bond and electrically ground an AOD pump with these grounding accessories. Specifications and drawing details available at www.all-flo.com.

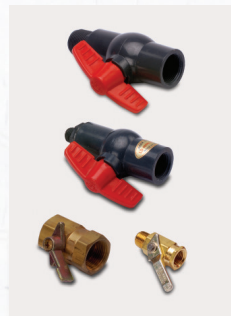

AIR FLOW CONTROL & NEEDLE VALVES

Adjust the speed and flow of the pump with an adjustable air pressure or needle valve. Specifications and drawing details available at www.all-flo.com.



VIBRATION ISOLATION

Reduces physical vibration from AOD pump operation. Specifications and drawing details available at www.all-flo.com.



SUCTION STRAINER

Liquid strainers for the suction side of AOD pumps. Specifications and drawing details available at www.all-flo.com.



HANDLES

Carrying handles for larger pumps www.all-flo.com.



LEAK DETECTION & METERING CONTROL

Additional accessories and options are available upon request. Details and specifications can be found in technical addendum or by contacting us directly.

MATERIALS OF CONSTRUCTION

WETTED PUMP MATERIALS

PTFE

PTFE or polytetrafluoroethylene is a thermoplastic polymer that is inert to most chemicals. Has average abrasion resistance. Temperature range 40°F to 220°F (4 to 104°C). PTFE is an FDA accepted material.

Polyethylene

Polyethylene is a thermoplastic polymer with superior chemical resistance. It has excellent abrasion resistance. Temperature range 32 to 158°F (0 to 70°C).

Polypropylene

Polypropylene is a good, general purpose plastic material used in a wide variety of pumping applications. All-Flo does not use glass fillers in the polypropylene. (Hydrofluoric acid and similar chemicals will attack glass fillers.)

Temperature range 32 to 180°F (0 to 82°C).

Natural polypropylene needs to be protected from direct sunlight. Natural polypropylene will allow light to pass through to the pumped material. (Not suitable for UV sensitive paints or inks)

PVDF

Polyvinylidene fluoride or PVDF is a specialty plastic material in the fluoropolymer family and is used generally in applications requiring the highest purity, strength, resistance to solvents, acids, bases and low smoke generation during a fire event.

Temperature range 0 to 250°F (-18 to 181°C). PVDF is an FDA accepted material.

Conductive Nylon

Conductive nylon is nylon with stainless steel fillers to allow the pump to be groundable.

Conductive nylon is used for pumping solvents that have the potential to cause an explosion from an electrical spark from static electricity.

Temperature range from 0°F to 150°F (-18 to 66°C).

Aluminum

Aluminum is a light weight metal used for many non-corrosive chemicals, oils and solvents. Do not use aluminum when pumping halogenated solvents. Temperature limit of 212°F (100°C).

316 Stainless Steel

316 stainless steel (ANSI CF-8M) is used on moderately corrosive liquids and halogenated solvents and has excellent abrasion resistance. Temperature limit of 212°F (100°C).

Electropolished & Passivated 316 Stainless Steel

Electropolishing or electrochemical polishing is a process that removes material from a metallic surface. Passivation is the formation of a hard non-reactive surface film that inhibits further corrosion by dipping the stainless steel in a nitric acid solution. Electropolished and passivated 316 SS pumps are normally used on food applications where FDA approved materials are required.

Temperature limit of 212°F (100°C).

WETTED ELASTOMERS

Buna-N (Nitrile)

Nitrile is a general purpose elastomer used on water and most oils. Temperature range 10°F to 180°F (-12 to 82°C).

Geolast®

Geolast® is an injection molded thermoplastic material with characteristics similar to Nitrile. Has excellent abrasion resistance. Temperature range 10°F to 180°F (-12 to 82°C).

EPDM

EPDM is a general purpose elastomer with good resistance to many acids and basis. Temperature range -40°F to 280°F (-40 to 138°C).

Santoprene®

Santoprene® is an injection molded thermoplastic material with characteristics similar to EPDM. Has excellent abrasion resistance. Temperature range -40°F to 225°F (-40 to 107°C).

Viton®

Viton® is an elastomer with good corrosion resistance to a wide variety of chemicals. Temperature range -40°F to 350°F (-40 to 177°C).

PTFE

PTFE or polytetrafluoroethylene is a thermoplastic polymer that is inert to most chemicals. Has average abrasion resistance. Temperature range 40°F to 220°F (4 to 104°C). PTFE is an FDA accepted material.

FDA Nitrile, FDA EPDM, FDA Viton®, FDA Santoprene® and FDA Hytrel® are FDA accepted materials.

Contact factory directly regarding higher temperature applications.

DATA ADDENDUM

COMPATIBLE DATA ADDENDUM CONTAINS:

- PERFORMANCE CURVES
- PUMP SPECIFICATIONS
- DIMENSIONAL DRAWINGS
- PART NUMBERS

DATA ADDENDUM CAN BE DOWNLOADED AT WWW.ALL-FLO.COM

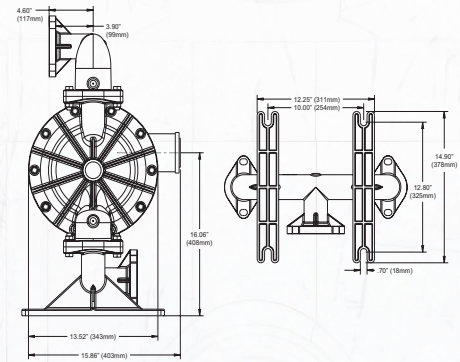
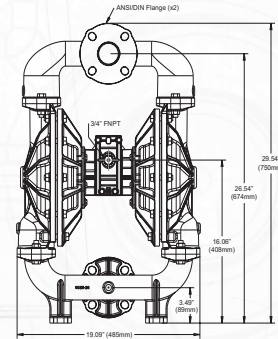
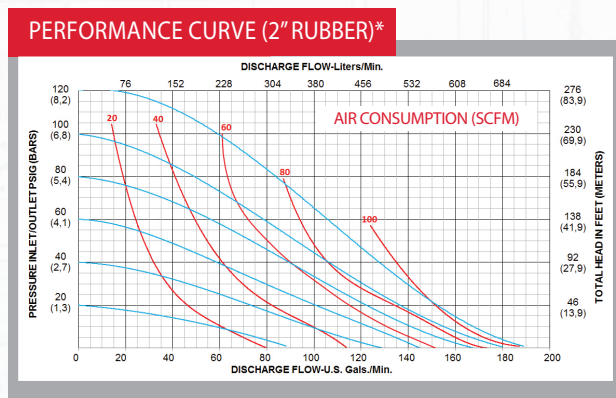

NO MATTER THE APPLICATION, ALL-FLO PUMPS

WORKHARDER.

ALL-FLO PUMPS DELIVER UNSURPASSED PERFORMANCE AND RELIABILITY

When you work hard to make a better pump, the result is pumps that work harder. At All-Flo, we make rugged, lube-free, non-stall/freeze air systems work as reliably as they do efficiently. Providing the versatility, durability and reliability that will meet virtually any application need. And we offer a wide range of materials and options that allow you to customize a model to meet your specific needs. So when your application calls for a pump that works harder, call on All-Flo.

Viton® is a registered trademark of DuPont Performance Elastomers L.L.C.
Geolast® is a registered trademark of ExxonMobil Chemical Co.
Santoprene® is a registered trademark of ExxonMobil Chemical Co.
Teflon® is a registered trademark of DuPont Performance Elastomers L.L.C.





AUTO/PLATING & FINISHING



CERAMIC SLIP / GLAZE



CHEMICAL / PETROCHEMICAL



FOOD & BEVERAGE



MINING



OEMS



OIL & GAS / REFINERY



PAINT & COATING

ALL-FLO is committed to the pursuit of designing and manufacturing the highest quality product available to industry. Since the beginning in 1986, All-Flo engineers have used their extensive knowledge of today's engineered materials, advanced air system logic and manufacturing techniques to develop the superior group of lube-free, air-operated diaphragm pumps found in this catalog. Every pump is performance engineered and quality built to provide trouble-free service under the toughest conditions.



7750 Tyler Blvd.
Mentor, Ohio 44060
phone: 440.354.1700
fax: 440.354.9466
www.all-flo.com

YOUR AUTHORIZED ALL-FLO DISTRIBUTOR